

HansDampf **gold**
The FlexiCombi

Combisteamer HansDampf® gold with two FlexiCombi operating concepts. Manual or automatic cooking for the most used cooking methods in commercial kitchens.

Manual operation Steaming, Convection, Combisteaming and Perfection.

Automatic with 9 autoChef cooking categories from meat to Perfection- the climate regeneration.

HansDampf offers the choice of cooking functions with convection and pressureless fresh steam either separately, one after the other or combined.



Technical highlights

Cooking chamber door with triple glazing

Energy saving - because of highly effective insulation. Work safety - due to low outside temperature. Perfect hygiene - due to a smooth, easy to clean inner surface

FlexiRack®

The flexibility and capacity concept 1/1GN crosswise or lengthwise insert or FlexiRack special sizes for an capacity increase up to 50%*.



316 – durable hygiene cooking chamber

Made from corrosion resistant chrome nickel steel, welded with innovative robot welding technology, hygienic, joint free and with rounded off corners.

autoChef automatic Cooking

Automatic cooking with 9 categories. From the meat category through to Perfection the cooking climate-Regeneration.



SES - Steam Exhaust System

The safety system. The steam is sucked out of the cooking chamber at the end of the cooking programme. No troublesome escape of steam when opening the door at the end of the cooking time.

WaveClean®

Safe - the detergent is in a cartridge sealed with protective wax. Easy - insert the cartridge, ready. Economical: Water consumption app.50l.



AtmosControl, climate control

An individually controllable cooking chamber climate with temperature and humidity measurement and active humidification and dehumidification, for crispy and juicy cooking results.

PHleco with DynaSteam

The dynamic steam generating system with heat recovery. The steam volume is dynamically controlled according to each cooking process



RackControl

Multi timer for monitoring of different foods cooking simultaneously. Up to 5 different times storable in RackControl programs.

Ready2Cook

Preheat, cool down, and ideal climate preparation combined in one function. Ideal conditions for perfect cooking at the push of a button.



* compared to HD with GN 1/1

Subject to change without notice



Master of Performance

HansDampf®

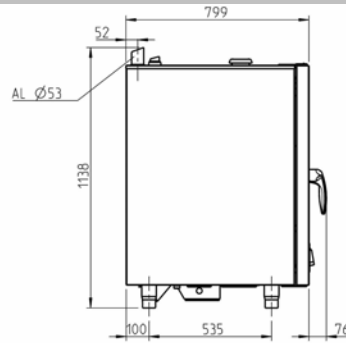
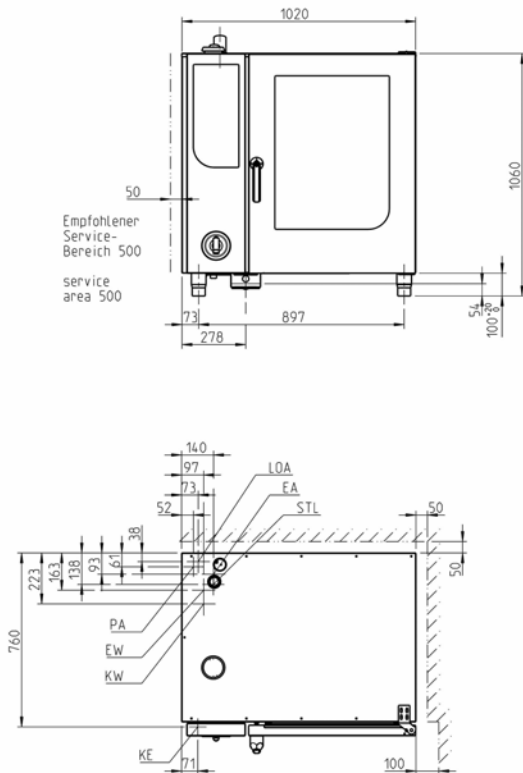

GA	Gas connection
EA	Electrical connection
STL	Control line
LOA	Performance optimization system
PA	Equipotential bonding
KE	Network interface
KW	Cold water
EW	Soft water
A	Drain water
AL	Exhaust air

Further features

- CombiPilot one-hand operating concept
- Manual operating concept 8cooking modes:
 - Soft steaming, steaming, Express steaming, convection, combi-steaming Perfection, low temperature cooking, delta-T- coking
 - Autoreverse fan for exceptional uniformity
 - Six air- speeds programmable
 - StepMatic up to 20 cooking steps combinable
 - Up to 350 cooking programs can be saved (autoChef+own)
 - Program protection
- Manual humidification
- Automatic programmable humidification
- Programmable rest time
- Programmable step signal
- Info-monitor display for cooking chamber humidity and categories
- Multi-function display for the best visibility and easy operation
- Multipoint core temperature measurement up to 99°C
- Manual cleaning program
- Integrated automatic shower hose
- Serial interface RS232 and RS 485
- Integrated HACCP memory for up to 200 cooking cycles
- High- efficiency heat exchanger
- Motor break
- Integrated fat separator
- Pulsed fan
- Halogen cooking chamber lighting, with flashing function
- Removable door seal- can be changed by customer
- Contact free door switch
- Door with latching position and end stop
- Foreign languages
- Service diagnostics program
- Timer with start time in real time
- VFD Monitor with plain text and graphic symbols
- Direct drain connection possible
- Rack inserts for FlexiRack and for GN1/1 crosswise insertion
- Fan forced gas burner
- Approvals: CE, GS, UL, CSA, FCC

Technical data

Dimensions: (BxTxH)	1020x799x1060 mm
Connected load gas	18 kW
Voltage / connected load electr.	230 V 3N PE AC / 0,8 kW
Fuse protection	1x16 A
Water connection PHI	G3/4 A max. 5°dH 0,89mmol/l
Water connection miscellan.	G3/4 A
Waterpressure	200 - 600 kPa (2-6 bar)
Drain connection	DN 50 (50mm, 2")
Weight	167 kg
Material housing	1.4301 AISI 304
Material cooking chamber	1.4405 AISI 316
Cooking capacity:	
FlexiRack (530 x 570 mm)	10x 65 deep
Gastronorm (530 x 325 mm)	10x 65 deep
Baking standard (600x400 mm)	
Plates Ø28 cm on FR-grids	40
Plates Ø32 cm - plate trolley	40
Heat emission latent VDI 2052	3240 W/h
Heat emission sensitive "	3240 W/h
Protection type	IPX5

Options / accessories

- Door hinged to the left
- Stacking kit to combine 2 HansDampf 6+6 or 6+10
- Flow operated safety (exhaust stack)
- FlexiRack® special trays and grids
- Banqueting system
- Under frames and cupboards
- Two-in-one cleaner/ rinse cartridges
- Two- step safety door lock
- Marine version
- Special voltages